

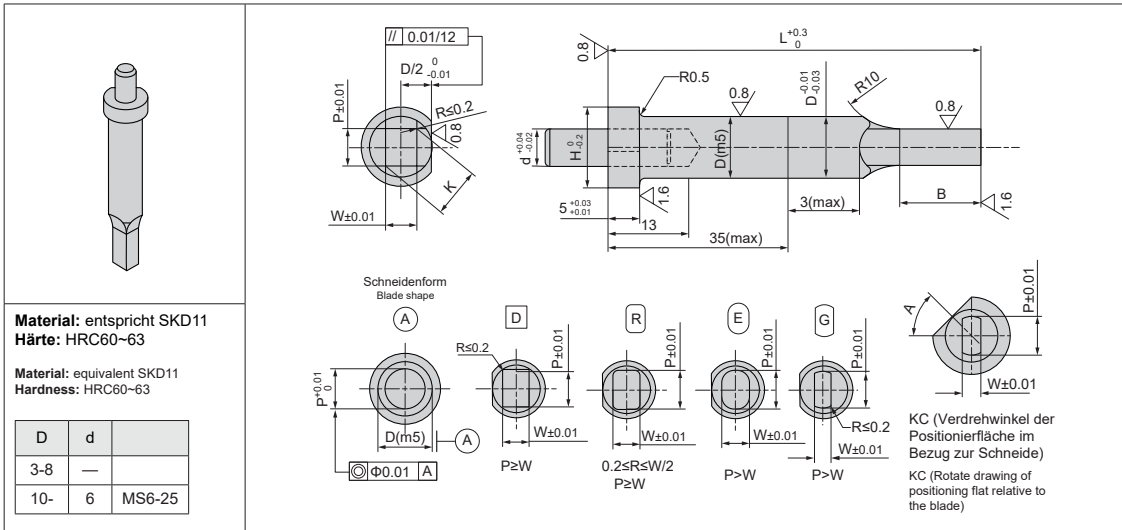

DM-PSPS



Bestell-Nr. Catalog No.			D	L	Abmessung in 0,01 mm Schritten Dimensions span 0.01mm		Abmessung in 0,01 mm Schritten (Dimensions span) 0.01 mm D R E G		H	B
Typ Type	Schneiden- form Blade shape	Schneidenlän- ge Blade length			P(A)	P.Kmax	P.Wmin			
DM- PSPS		S	3	90 100	1.00-2.99	—	—	5	8	
			4	90 100	1.00-3.99	3.97	1.00	7		
			5	90 100	2.00-4.99	4.97	1.20	8		
			6	90 100	2.00-5.99	5.97	1.50	9		
			8	110 120	3.00-7.99	7.97	2.00	11	13	
			10	110 120 130 140 150	3.00-9.99	9.97	(2.50)	13		
			13	110 120 130 140 150	6.00-12.99	12.97	3.00	16		
			16	110 120 130 140 150	10.00-15.99	15.97	4.00	19		
			20	110 120 130 140 150	13.00-19.99	19.97	5.00	23	19	
			25	110 120 130 140 150	18.00-24.99	24.97	6.00	28		
			32	130 140 150	20.00-31.99	31.97	7.00	35		
			38	130 140 150	28.00-37.99	—	—	41		
			45	130 140 150	35.00-44.99	—	—	48		

Bestell-Nr. Catalog No.			D	L	Abmessung in 0,01 mm Schritten Dimensions span 0.01mm		Abmessung in 0,01 mm Schritten (Dimensions span)0.01 mm D R E G		H	B
Typ Type	Schneiden- form Blade shape	Schneidenlänge Blade length			P A	P.Kmax	P.Wmin			
DM-PSPS		L	3	90 100	1.00-2.99	—	—	5	13	
			4	90 100	1.00-3.99	3.97	1.00	7		
			5	90 100	2.00-4.99	4.97	1.20	8		
			6	90 100	2.00-5.99	5.97	1.50	9		
			8	110 120	3.00-7.99	7.97	2.00	11	19	
			10	110 120 130 140 150	3.00-9.99	9.97	(2.50)	13		
			13	110 120 130 140 150	6.00-12.99	12.97	3.00	16		
			16	110 120 130 140 150	10.00-15.99	15.97	4.00	19		
			20	110 120 130 140 150	13.00-19.99	19.97	5.00	23	25	
			25	110 120 130 140 150	18.00-24.99	24.97	6.00	28		
			32	130 140 150	20.00-31.99	31.97	7.00	35		
			38	130 140 150	28.00-37.99	—	—	41		
			45	130 140 150	35.00-44.99	—	—	48		

Bestellnummer / Order Number

☎ Bestellnr. / Catalog No. - L - P - W - R

DM-PSPSAS8 - 120 - 10.5 - 3 - 0.2

KC A=30 **DM-PSPSAS8 - 120 - 10.5 - 3 - 0.2 - KC30**

