

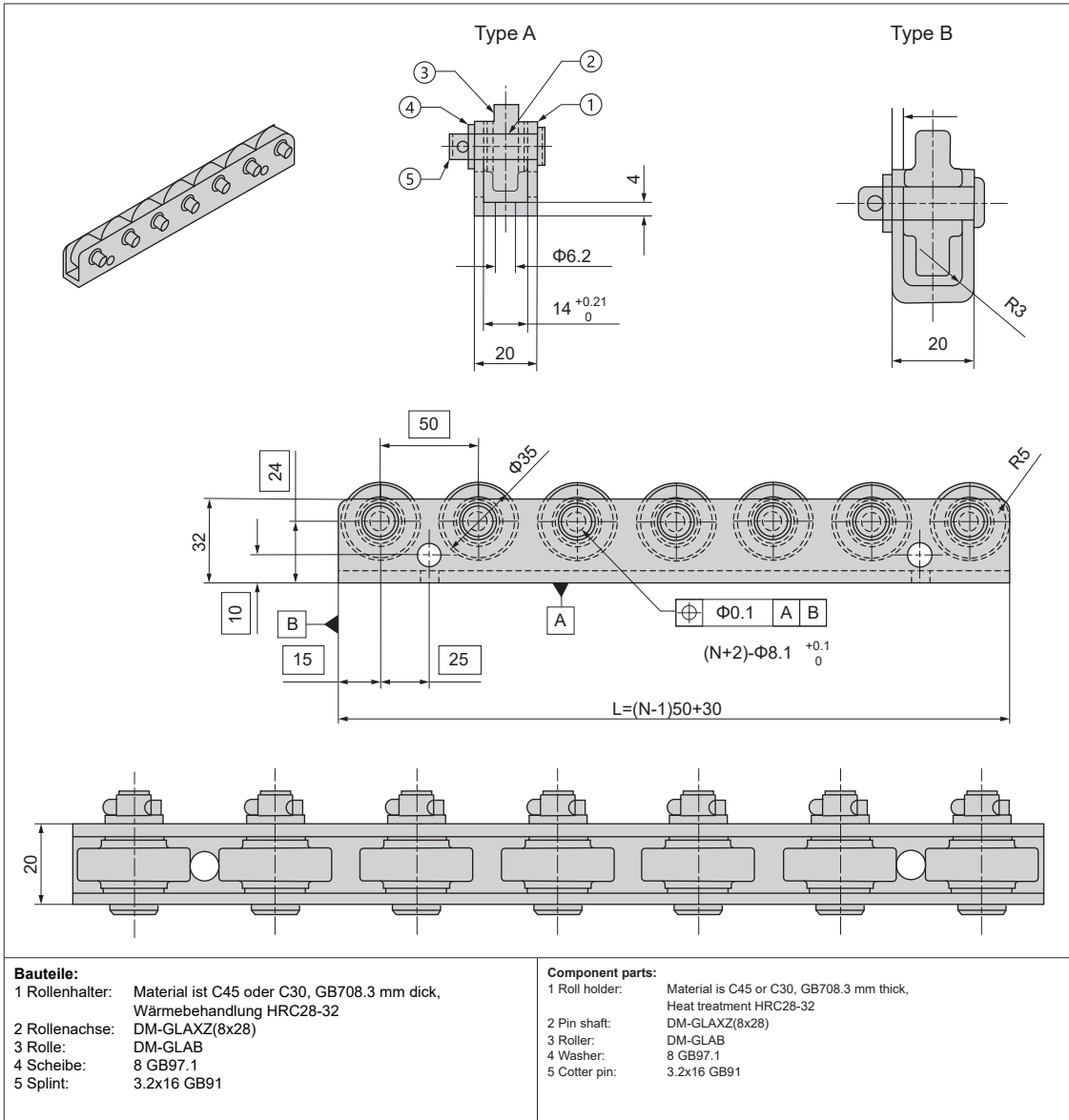

DM-GDA



N	5	6	7	8	9	10	11	12	13
L	230	280	330	380	430	480	530	580	630

Bestellnummer / Order Number

 Bestellnr. / Catalog No. - L - A/B
DM-GDA - 280 - A



DW-GDB

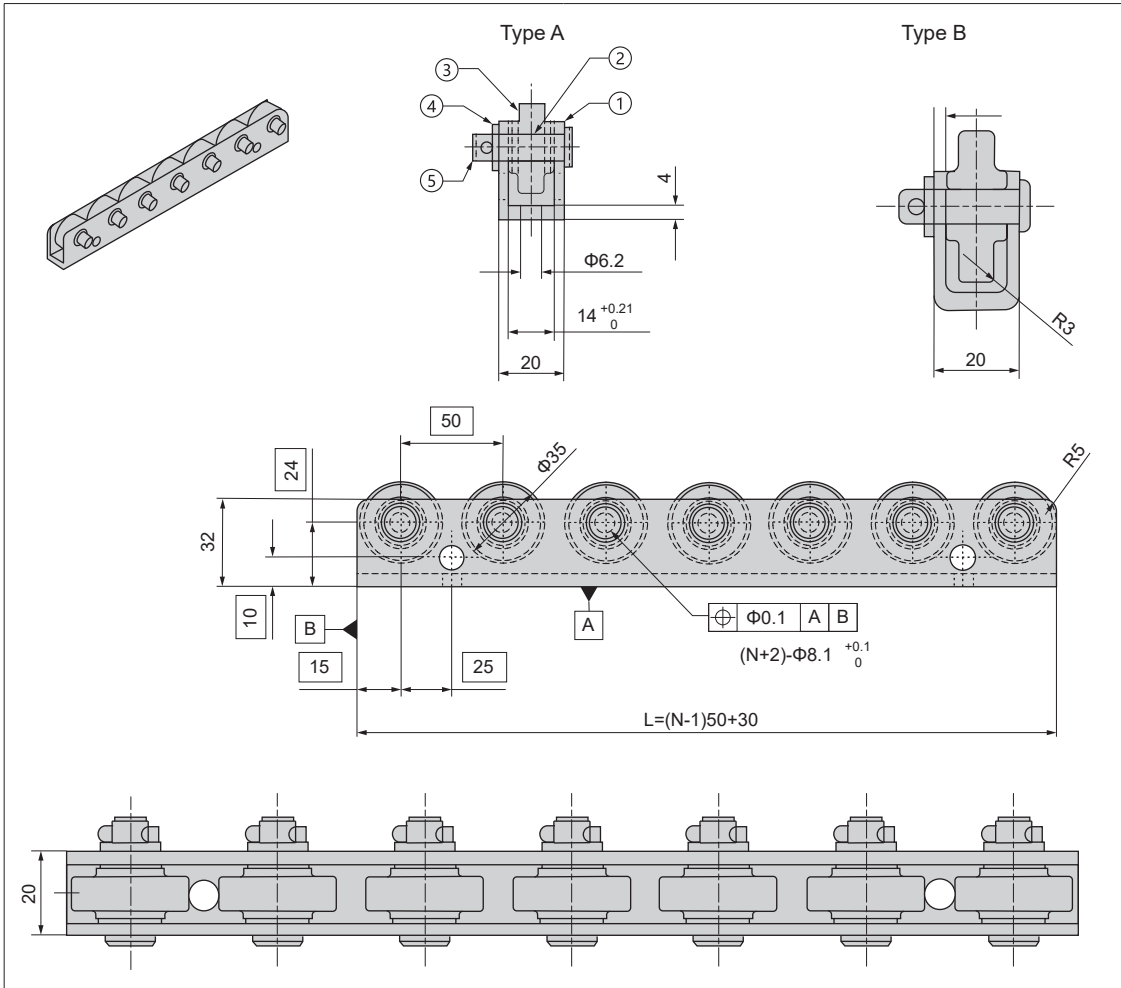

Bauteile:
 1. Rollenhalter: Material ist C45 oder C30, GB708.3 mm dick, Wärmebehandlung HRC28-32
 2. Rollenachse: DM-GLAXZ(8x28)
 3. Rolle: DM-GLAB
 4. Scheibe: 8 GB97.1
 5. Splint: 3.2x16 GB91

Component parts:
 1.Roll holder: Material is C45 or C30, GB708.3 mm thick, Heat treatment HRC28-32
 2.Pin shaft: DM-GLAXZ(8x28)
 3.Roller: DM-GLAB
 4.Washer: 8 GB97.1
 5.Cotter pin: 3.2x16 GB91

N	5	6	7	8	9	10	11	12	13
L	230	280	330	380	430	480	530	580	630

Bestellnummer / Order Number

 Bestellnr. / Catalog No. - L - A/B
 DM-GDB - 280 - A

