

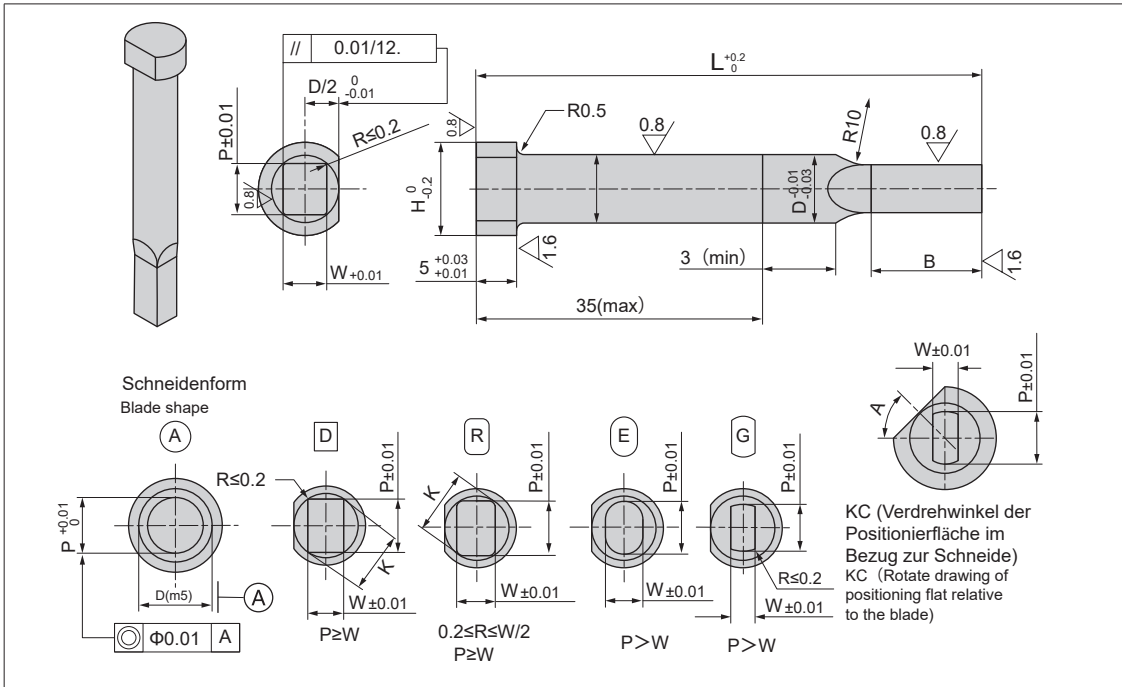



DM-PSP,DM-PSH,DM-PPH

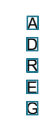
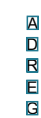
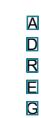

Bestell-Nr. Catalog No.			Schneidlänge Code S Blade length was S			Schneidlänge Code L Blade length was L			Abmessung in 0,01 mm Schritten Dimensions span 0.01mm A		Abmessung in 0,01 mm Schritten Dimensions span 0.01 mm D E E G		H
Type	Schneidform Blade shape	Schneidlänge Blade length	D	L	B	L	B	P	P.Kmax	P.Wmin			
DM-PSP DM-PSH DM-PPH		S	3	40 50 60 70 80	8	50 60 70 80	13	1.00~2.99	2.97	0.7	5		
			4	40 50 60 70 80		50 60 70 80		1.00~3.99	3.97	1.00	7		
			5	40 50 60 70 80		50 60 70 80		2.00~4.99	4.97	1.20	8		
			6	40 50 60 70 80		50 60 70 80		2.00~5.99	5.97	1.50	9		
			8	(40) 50 60 70 80 90 100		50 60 70 80 90 100		3.00~7.99	7.97	2.00	11		
			10	(40) 50 60 70 80 90 100		50 60 70 80 90 100		3.00~9.99	9.97	2.50	13		
		L	13	(40) 50 60 70 80 90 100	50 60 70 80 90 100	6.00~12.99	12.97	3.00	16				
			16	(40) 50 60 70 80 90 100	60 70 80 90 100	10.00~15.99	15.97	4.00	19				
			20	(40) 50 60 70 80 90 100	60 70 80 90 100	13.00~19.99	19.97	5.00	23				
			25	(40) 50 60 70 80 90 100	60 70 80 90 100	18.00~24.99	24.97	6.00	28				

Bestell-Nr. Catalog No.			Schneidlänge Code X Blade length was X		Abmessung in 0,01 mm Schritten Dimensions span 0.01mm A		Abmessung in 0,01 mm Schritten Dimensions span 0.01mm D E E G		H	B	Type	Material
Type	Schneidform Blade shape	Schneidlänge Blade length	D	L	P	P.Kmax	P.Kmax					
DM-PSP		X	3	50 60 70 80	1.00~2.99				5	19	DM-PSP	entspricht / equivalent SKD11 HRC60-63
			4	50 60 70 80	1.00~3.99							
			5	60 70 80	2.00~4.99							
			6	60 70 80	2.00~5.99							
			8	60 70 80 90 100	3.00~7.99							
DM-PSH		X	10	60 70 80 90 100	3.00~9.99				11	30	DM-PSH	SKH51 HRC61~64
			13	60 70 80 90 100	6.00~12.99							
			16	70 80 90 100	10.00~15.99							
DM-PPH		X	20	70 80 90 100	13.00~19.99				19	40	DM-PPH	HRC64~67 Powder high speed steel
			25	70 80 90 100	18.00~24.99							

Bestellnummer / Order Number

 Bestellnr. / Catalog No. - **L** - **P** - **W** - **R**

DM-PSPAS13 - **80** - **10.5** - **7.34** -

KC A=45 **DM-PSPAS13** - **80** - **10.5** - **7.34** - - **KC45**



DM-PGPS

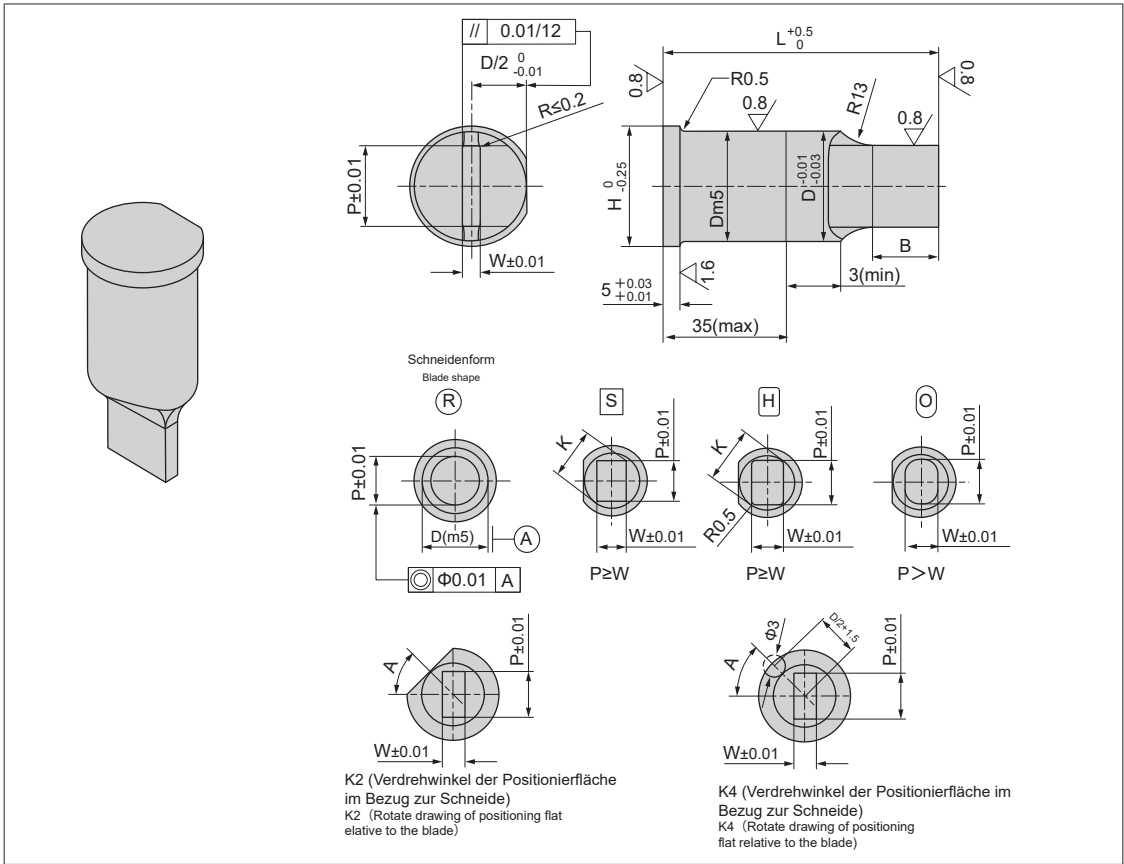

Bestell-Nr. Catalog No.		D	Schneidenlänge Blade length(B)	L	Abmessung in 0,01 mm Schritten Dimensions span 0.01 mm R		Abmessung in 0,01 mm Schritten Dimensions span 0.01 mm S H O		H	M Material
Typ Type	Schneidenform Blade shape				P	P.Kmax	P.Wmin			
DM-PGPS	R	4	8 10	40 50 56 60 63	1.00~3.97	—	—	7	A2 M2	
		5	8 10 13	40 50 56 60 63 70 71	1.30~4.97	4.97	1.30	8		
		6		40 50 56 60 63 70 71 80	1.60~5.97	5.97	1.60	9		
		8	40 50 56 60 63 70 71 80	2.50~7.97	7.97	2.00	11			
	S	10	10 13 19	50 56 60 63 70 71 80 90 100	3.00~9.97	9.97	2.50	13		
		13		50 56 60 63 70 71 80 90 100	5.00~12.97	12.97	4.50	16		
		16	13 19 25	56 60 63 70 80 90 100	8.00~15.97	15.97	6.00	19		
		20		56 60 63 70 80 90 100	12.00~19.97	19.97	8.00	23		
	H	25	19 25 32	70 71 80 90 100	16.50~24.97	24.97	10.00	28		
		32		70 71 80 90 100	24.00~31.97	31.97	12.50	35		
		38	19 25 32	70 71 80 90 100	28.00~37.97	37.97	14.00	41		
		40		70 71 80 90 100	30.00~39.97	39.97	14.00	43		
		45	25 32	80 90 100	35.00~44.97	44.97	16.00	48		
		50			40.00~49.97	49.97	20.00	53		
		56			45.00~55.97	55.97	25.00	59		
		63			50.00~62.97	62.97	30.00	66		

Typ Type	(Material)	(Härte) (Hardness)
DM-PGPS	A2(DC53)	HRC60-63
	M2(SKH51)	HRC61-64

Bestellnummer / Order Number

	Bestellnr. / Catalog No.	-	D	-	B	-	L	-	P	-	W	-	M	-	K2/K4
	DM-PGPSR	-	32	-	19	-	70	-	24	-	6	-	A2	-	K2
K2/K4 A=45	DM-PGPSR	-	32	-	19	-	70	-	24	-	6	-	A2	-	K2 - 45



DM-PSS(H/P)

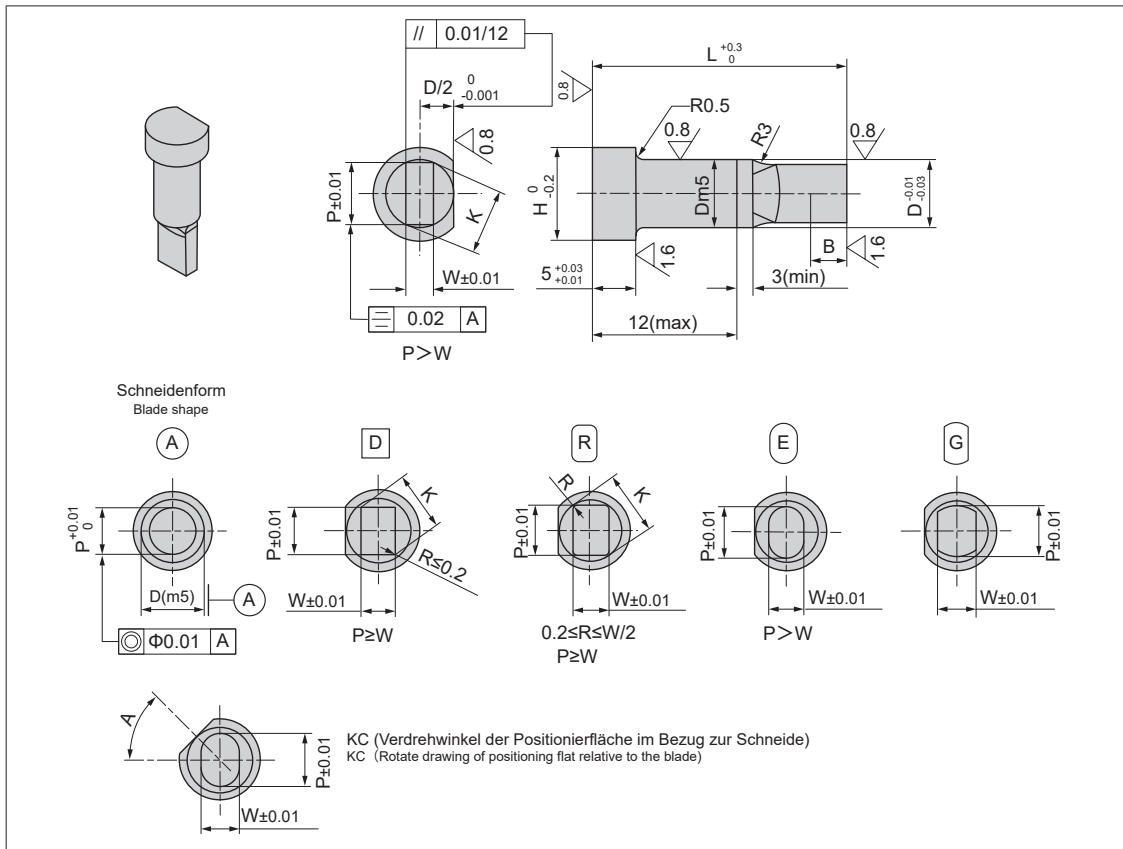

Bestell-Nr. Catalog No.			L	Abmessung in 0,01 mm Schritten Dimensions span 0.01 mm (A)	Abmessung in 0,01 mm Schritten Dimensions span 0.01 mm D R E G		H	B
Type	Schneiden- form Blade shape	Schneiden- länge Blade length		P	P.Kmax	P.Wmin		
DM-PSS DM-PSSH DM-PSSP		S	3	1.00-2.99	2.95	1.00	5	8
			4	2.00-3.99	3.95	1.20	7	
			5	2.00-4.99	4.95	1.20	8	
			6	2.50-5.99	5.95	1.50	9	
			8	5.00-7.99	7.95	2.00	11	
			10	7.00-9.99	9.95	2.50	13	
DM-PSS DM-PSSH DM-PSSP		L	3	1.00-2.99	2.95	1.00	5	13
			4	2.00-3.99	3.95	1.20	7	
			5	2.00-4.99	4.95	1.20	8	
			6	2.50-5.99	5.95	1.50	9	
			8	5.00-7.99	7.95	2.00	11	
			10	7.00-9.99	9.95	2.50	13	

Type	Material
DM-PSS	entspricht / Equivalent SKD11 HRC60-63
DM-PSSH	SKH51 HRC61-64
DM-PSSP	Pulver-Schnellarbeitsstahl Powder high speed steel

Bestellnummer / Order Number

 Bestellnr. / Catalog No. - **L** - **P** - **W** - **R**

DM-PSSAS4 - **35** - **2.00** - **1.20** - **0.2**

KC A=45 **DM-PSSAS4** - **35** - **2.00** - **1.20** - **0.2** - **KC45**

