

SX-QGDLE40S

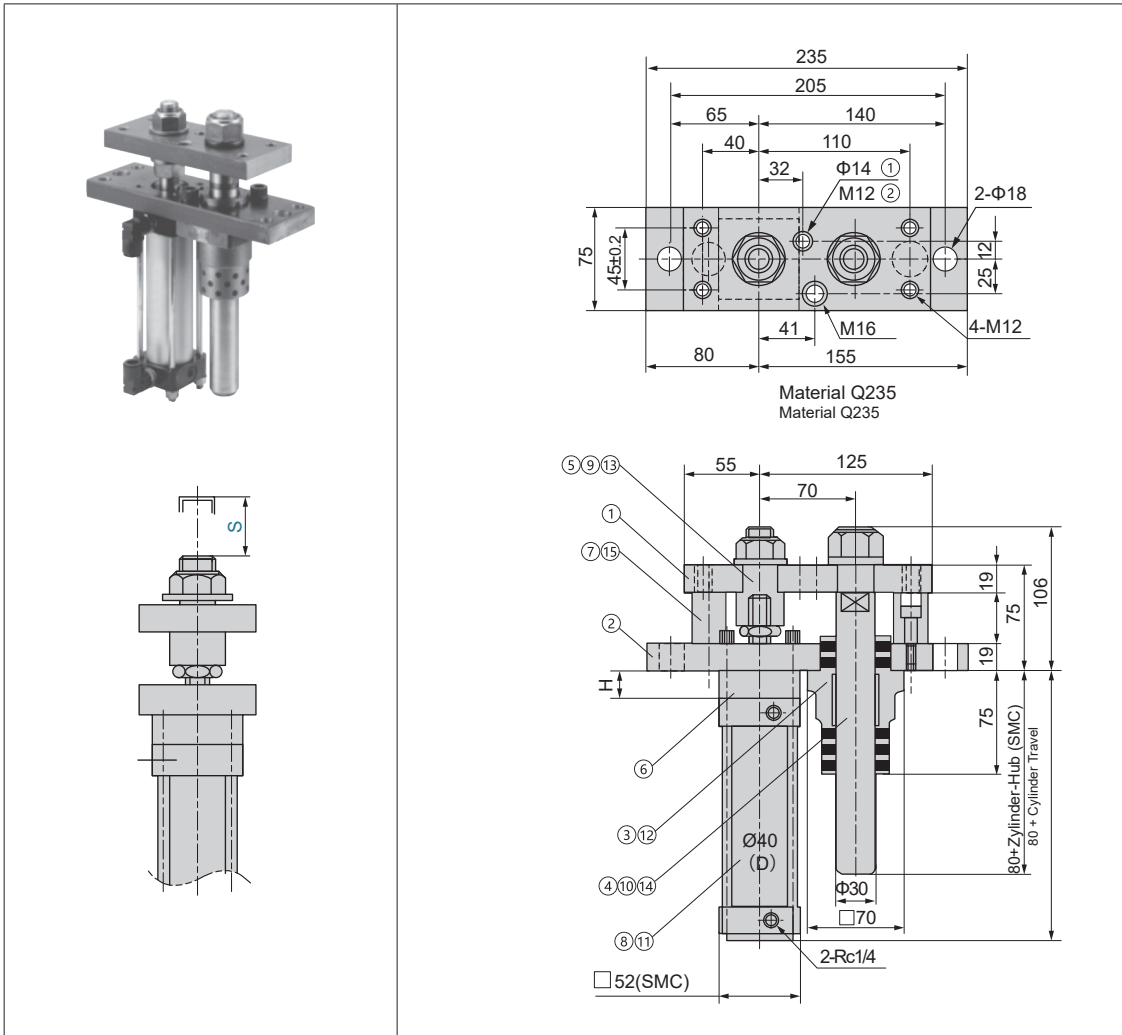

⑥ Block

Application	D	H
SX-QGDLE 40S	40	10
		20
		30
		40

Material : Q235



Stückliste

Table of Components

Nr. No.	Beschreibung Description	Menge Qty	Material und Bemerkung Material and Remark
①	Heberplatte Lifter Plate	1	Q235
②	Zylinderhalteplatte Cylinder Holder Plate	1	Q235
③	Buchsenhalter Bushing Holder	1	HT300+Graphit/With Graphite
④	Führungsstift Guide Pin	1	C45 HRC55-60
⑤	Verbindungsstück Joint	1	Q235
⑥	Block	1	Q235
⑦	Stopper	2	Urethane
⑧	Druckluftzylinder Air Cylinder	1	MB40(SMC)
⑨	Mutter Nut	1	M20
⑩	Mutter Nut	1	M24
⑪	Innensechskantschraube Hexagon Socket Head Bolt	4	M6
⑫	Innensechskantschraube Hexagon Socket Head Bolt	2	M12x35
⑬	Scheibe Washer	1	M20
⑭	Federscheibe Spring Washer	1	M24
⑮	Innensechskantschraube Hexagon Socket Head Bolt	2	M8x20

Hub S / Stroke S	10	20	30	40	50	60	70	80	90	100	110	120	130	140	150
Blockhöhe H / Block height	40	30	20	10	—	40	30	20	10	—	40	30	20	10	—
Zylinderhub / Cylinder stroke	50					100					150				

Hub S / Stroke S	160	170	180	190	200	210	220	230	240	250
Blockhöhe H / Block height	40	30	20	10	—	40	30	30	10	—
Zylinderhub / Cylinder stroke	200					250				

Bestell-Nr. Catalog No.	Zylinderdurchmesser D/ Cylinder diameter D	Hub S in 10 mm Schritten Stroke S in 10 mm increments
SX-QGDLE 40S	40	10~50
		60~100
		110~150
		160~200
		210~250

Bestellnummer / Order Number

	Bestellnr. / Catalog No.	-	S
	SX-QGDLE 40S	-	60

