

DM-CTZA

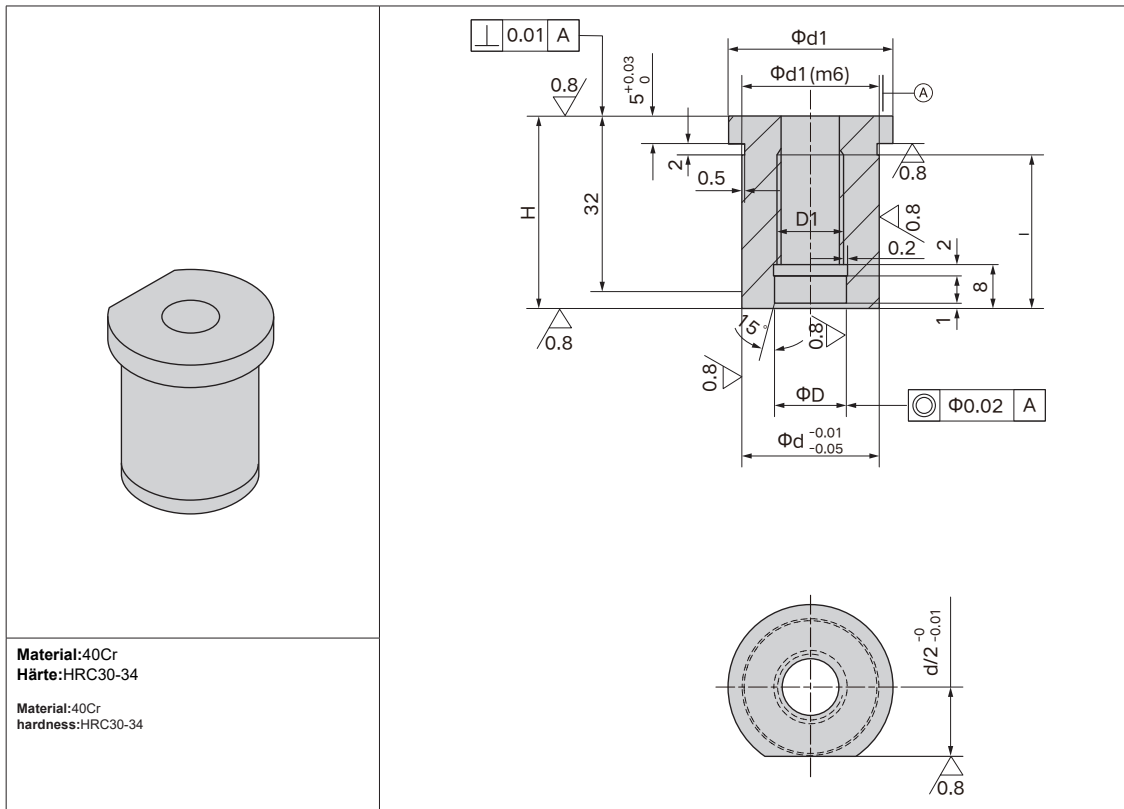

Material:40Cr
Härte:HRC30-34

Material:40Cr
hardness:HRC30-34

D (H6)		d (m6)		D1(6H)	d1	l	H
9	+0.009 0	20	+0.021 +0.008	M8X1.0	25	28	35
13	+0.011 0	25		M12X1.25	30		
15	+0.013 0	32	+0.025 +0.009	M14X1.5	37		

Bestellnummer / Order Number

Bestellnr. / Catalog No. -
 d -
 H
DM-CTZA - **20** - **35**

