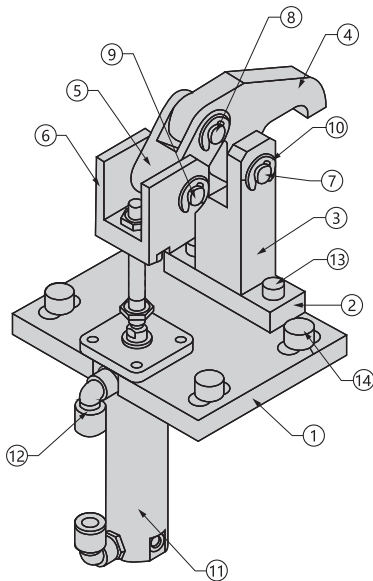
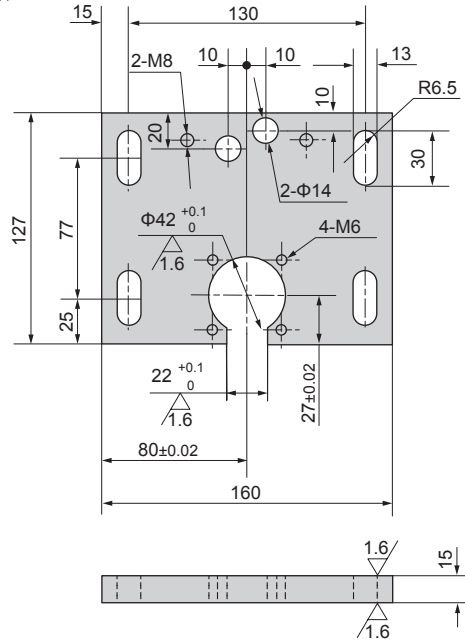
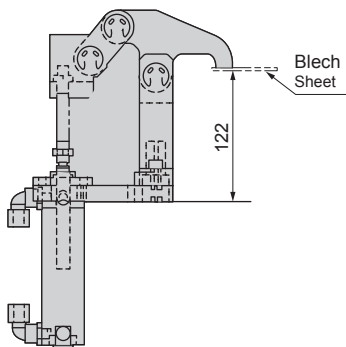
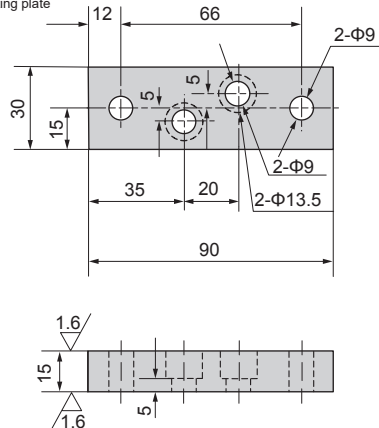

DM-BLJJHA

1. Befestigungsplatte
1. Fixing plate

2. Kleine Montageplatte
2. Small mounting plate

Teil 1 - 9, Material C45			
Teil 10	Sicherungsring 6x	GB896-86	d12
Teil 11	Zylinder	CG1FN32-75	
Teil 11	Befestigung 4x	GB70	M6X20
Teil 12	Verbinder 2x	KQL10-01S	
Teil 13	Schraube 4x	GB70	M8X30
Teil 14	Schraube 4x	GB70	M12X40

Part number 1 to 9, and number for each one, material is 45			
Part10	Opening ring 6	GB896-86	d12
Part11	Cylinder 1	CG1FN32-75	
Part11	Fixation Bolt 4	GB70	M6X20
Part12	Connector 2	KQL10-01S	
Part13	Bolt 4	GB70	M8X30
Part14	Bolt 4	GB70	M12X40

Bestellnummer / Order Number

Bestellnr. / Catalog No.

DM-BLJJHA