

AU-PSLB19-306

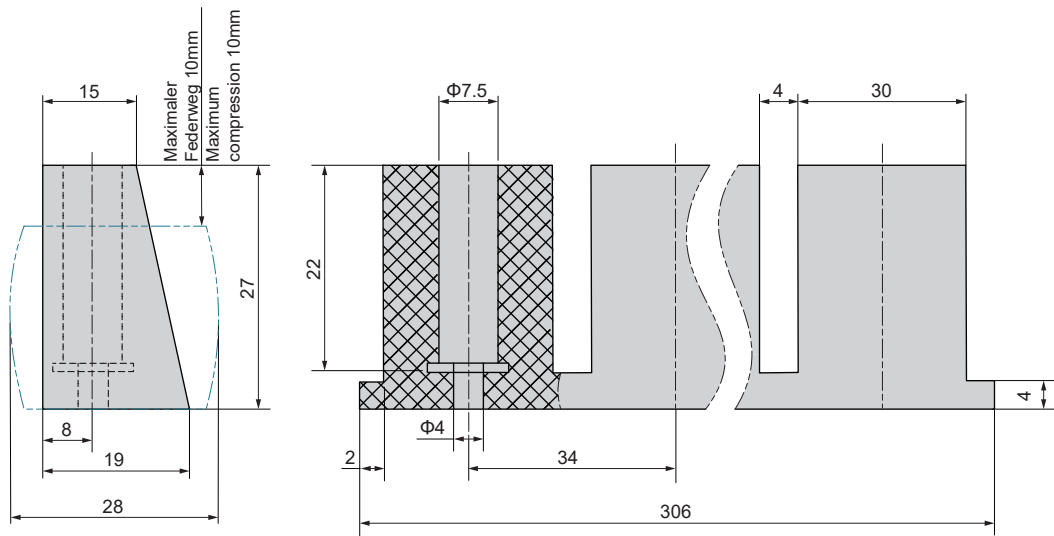

Material: Urethan
Härte: Shore A80±5

Material: Urethane
Hardness: Shore A80±5

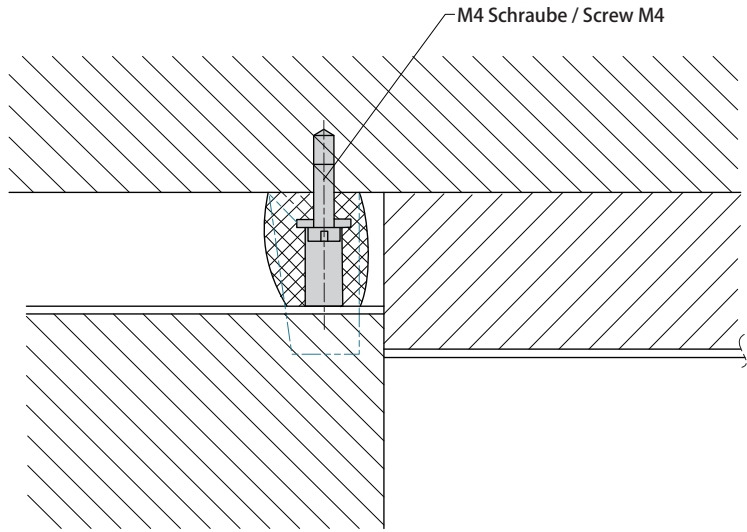

Bestellnummer / Order Number



Bestellnr. / Catalog No.

AU-PSLB19-306



EM24-PSLA19-310

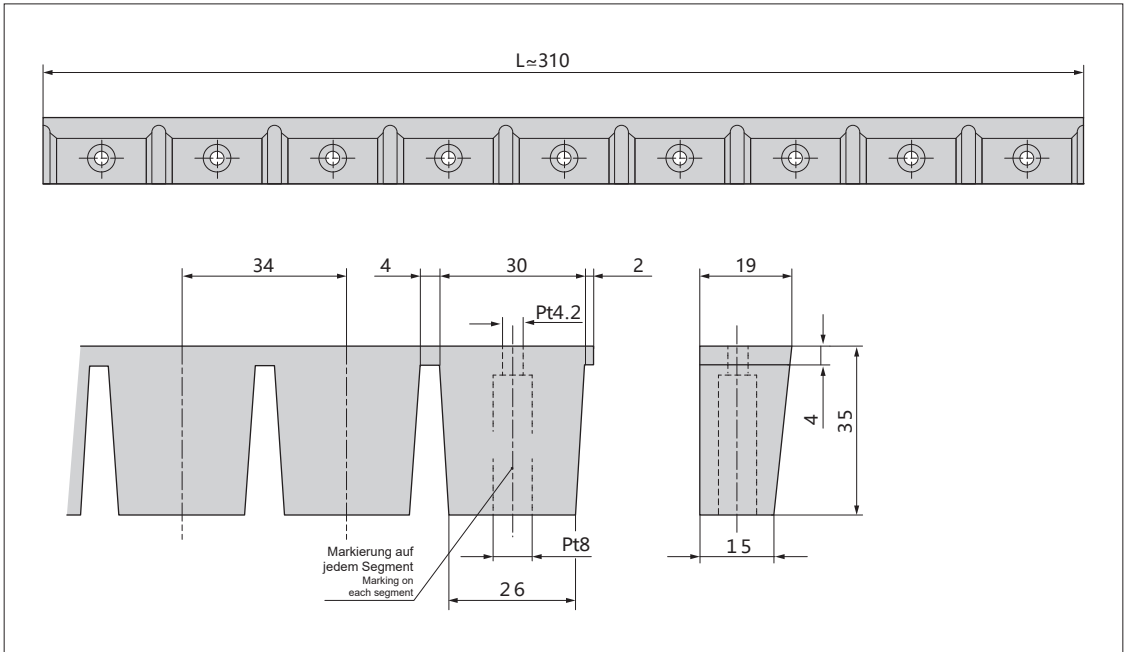

Bruchfestigkeit:

Crushing strength:

Verwendung: 8 mm Hub: Anzug + Durchdringung + Blechdicke

Use: stroke 8 mm: tightening + penetration + thickness sheet

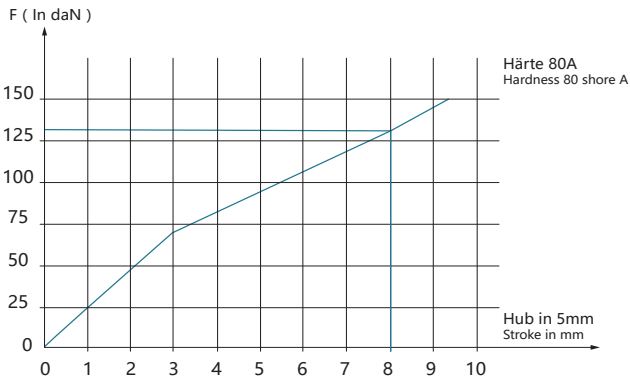

Bestellnummer / Order Number



Bestellnr. / Catalog No.

EM24-PSLA19-310

EM24-PSLA19-M5

Befestigungsklemme:

Fastening nip:

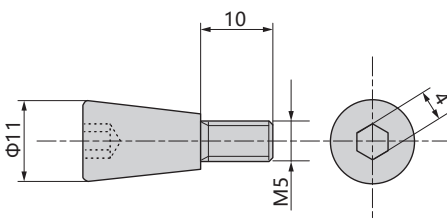

Bestellnummer / Order Number



Bestellnr. / Catalog No.

EM24-PSLA19-M5



E24-PSLA32-400
E24-PSLB32-400
Hinweis:

- Vor der Stabilisierung: H = 65
- Nach der Stabilisierung: H = 63
- Zur Berechnung von Hüben und Festigkeiten stets die stabilisierte Höhe berücksichtigen.

Verwendung:

- Polyurethan 80 shore A für Blechstärken von < 0,97 mm
- Polyurethan 90 shore A für Blechstärken von ≥ 0,97 mm

Note:

- Before stabilisation: H = 65
- After stabilisation: H = 63
- To calculate strokes and strengths, always take the stabilised product into consideration.

Use:

- Polyurethane 80 shore A for panel thickness < 0.97 mm
- Polyurethane 90 shore A for panel thickness ≥ 0.97 mm

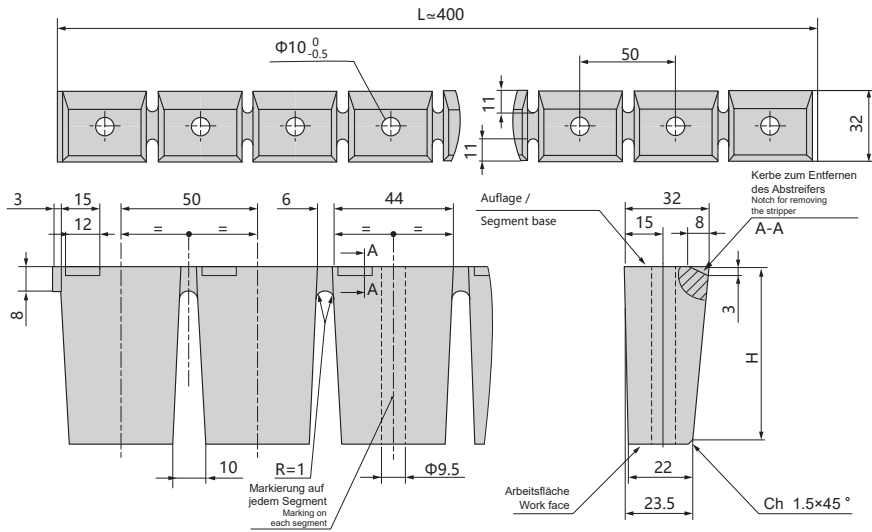

Material:

Material:

Material	Bestell-Nr. Catalog No.
90 shore A	E24-PSLA32-400
80 shore A	E24-PSLB32-400

Bruchfestigkeit:

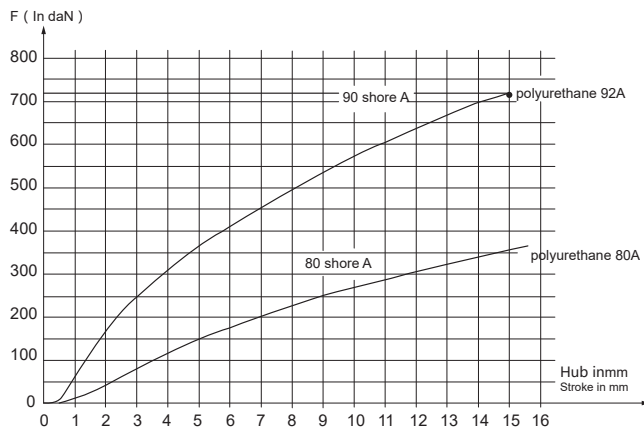
Crushing strength:



EM24-PSLA32-400

EM24-PSLB32-400

Der Abstreifer wird von den Schneidstempeln gestützt:

The strippers are supported against the blades:

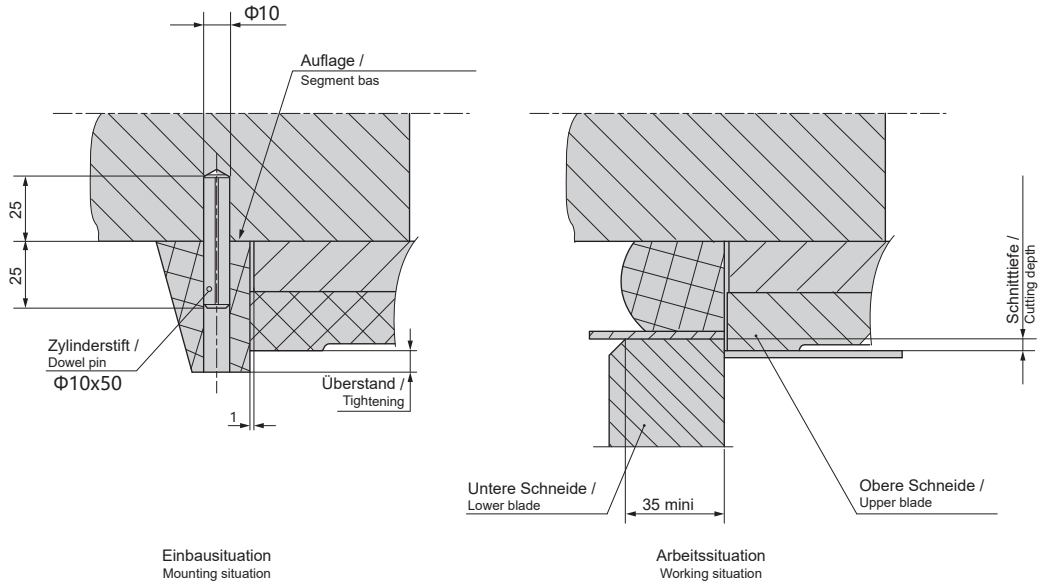

Hinweis: Um eine Verformung der Teile zu vermeiden, Bohrungen (z.B. Schrauben-, Stiftlöcher) am Lochstempel oder an Einsätzen in der Nähe des Abstreifers vermeiden (s. unten).

Note: To prevent distorting the parts, do not include holes or clearances (e.g. screws, pins) on the punch or lower blades in the bearing zone of the stripper (see below).

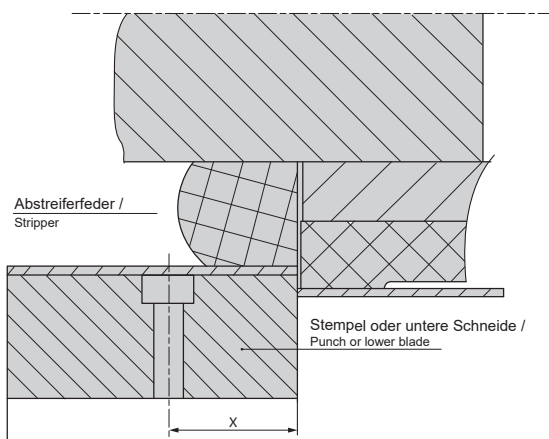

Min. Werte der Größe X Min values of size X		
Mit Schraube With screw	Maß Dimension	X
	M12	40
	M16	45
	M20	48
Mit Stift With pin	Maß Dimension	X
	Φ12	36
	Φ16	38
	Φ20	40

Bestellnummer / Order Number



Bestellnr. / Catalog No.

EM24-PSLA32-400

EM24-PSLB32-400

